

(No Model.)

J. R. BACK.

METAL TURNING LATHE.

No. 341,207.

Patented May 4, 1886.

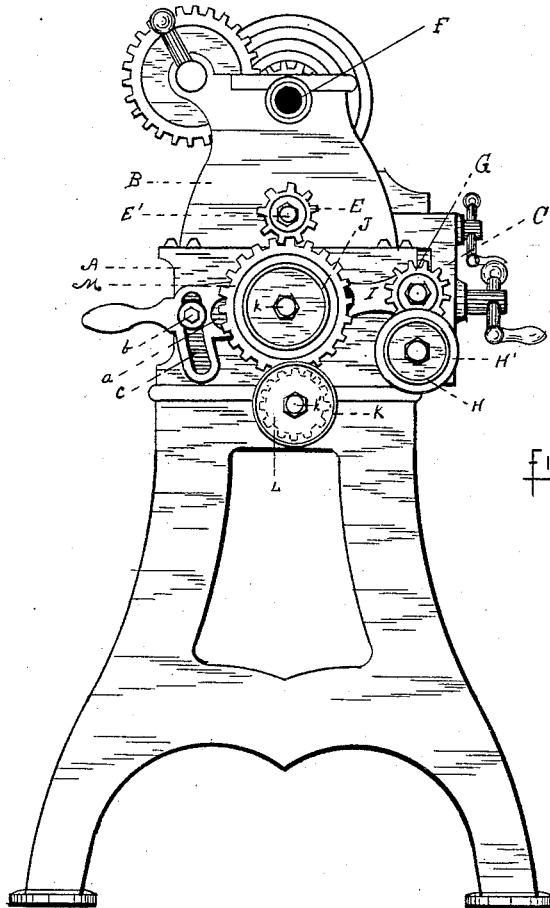

FIG. 1.

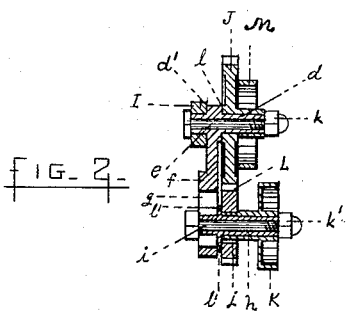

FIG. 2.

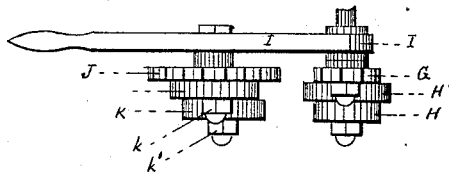

FIG. 3.

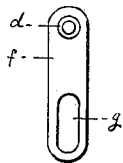

FIG. 4.

WITNESSES.

W. C. Steere
Rufus Bennett Fowler

INVENTOR.

John R. Back

UNITED STATES PATENT OFFICE.

JOHN R. BACK, OF WORCESTER, MASSACHUSETTS, ASSIGNOR OF ONE-HALF
TO FREDERICK E. REED, OF SAME PLACE.

METAL-TURNING LATHE.

SPECIFICATION forming part of Letters Patent No. 341,207, dated May 4, 1886.

Application filed December 14, 1885. Serial No. 185,572. (No model.)

To all whom it may concern:

Be it known that I, JOHN R. BACK, a citizen of the United States, residing at Worcester, in the county of Worcester and State of Massachusetts, have invented a new and useful Improvement in Metal-Turning Lathes, of which the following is a specification, containing a full, clear, and exact description of the same, accompanied by drawings representing a metal-turning lathe embodying my invention, and in which—

Figure 1 shows an end elevation. Fig. 2 is a sectional view of a portion of the mechanism for driving the feed-shaft. Fig. 3 is a top view of a portion of the mechanism for driving the feed-shaft, and Fig. 4 is a detached view of the slotted arm for holding the auxiliary pinion and driving-pulley.

Similar letters refer to similar parts in the several views.

My invention relates to the feeding mechanism of a metal-turning lathe; and it consists in the addition of a driving-pulley to the "intermediate gear" usually employed in driving the "leading-screw," from which a rotary motion is given the "feed-shaft;" also, in a gear and driving-pulley driven by the intermediate gear, by which a quicker motion is given to the feed-shaft, and in devices for holding the driving-pulleys, whereby a change of gears may be made and the speed of the feed-shaft varied.

A denotes the bed of the machine; B, the head-stock; C, the apron.

E is a gear upon a spindle, E', driven by the live-spindle F by gears within the head-stock, and not shown.

G is a gear on the leading-screw, and H H' are steps of a cone-pulley on the feed-shaft. The feed-shaft and the leading-screw are both held in bearings in front of the bed A, and not shown. A slotted lever, I, turning on the leading-screw as a pivot, carries the intermediate gear, J, which is brought into contact with the gear G by adjustment in the slot a, and held in contact with the driving-gear E by the bolt b in the concentric slot c.

Changes may be made in the relative sizes of the driving-gear E or the driven gear G, and the speed of the leading-screw varied relatively to the speed of the live-spindle.

This method of rotating the leading-screw is common in its essential features to all screw-cutting lathes. The relative positions of the several parts are, however, varied by different makers, in some cases the leading-screw being placed upon the rear side of the bed, with the feed-shaft upon the front side, requiring a different arrangement of the several parts than that shown in the accompanying drawings. All of them, however, employ an intermediate gear adjustable in its position, to allow the size of both the gears E and G to be changed.

Although my present invention relates only to the devices for rotating the feed-shaft, the mechanism relating to the rotation of the leading-screw has been described, as a portion of it is employed in the operation of the parts forming the subject of my invention. A usual method of rotating the feed-shaft has been to place on the spindle E' a cone-pulley, from which power is imparted to the cone-pulley H H' on the feed-shaft. This allows the speed of the feed-shaft to be varied only by the steps of the cone-pulleys. The intermediate gear, J, runs loose on a sleeve, d, held in the slot a of the lever I by a bolt, e, which clamps the lever I between the shoulder d' and the head of the bolt, and from the sleeve d depends an arm, f, having a slot, g, in which the sleeve h is similarly held by a bolt, i. Upon the sleeve h the belt-pulley K rotates, carrying upon its hub a pinion, L, meshing with the intermediate gear, J, and driving the pulley K by a spline, j. The nuts k and k' on the bolts e and i press against the ends of the sleeves d and h, and are large enough to hold the pulleys K and gear J in position on their respective sleeves, where they run loose between the nuts k k' and the shoulders l l'.

The speed of the belt-pulley K may be changed by changing the size of one or both of the gears E and L, the vibrating lever I permitting the intermediate J to be kept in mesh, and the radial slot g allowing the position of the gear L to be varied.

To the side or hub of the intermediate J, as may be most convenient, I attach a belt-pulley, M. The pulley K is in alignment with the step H and the pulley M with the step H' of the cone-pulley on the feed-shaft.

For work requiring a very slow speed of the cutting-tool I drive the feed-shaft by the step H' and the pulley M, which has a very slow speed as driven by the large gear J and the pinion E. The gear J being adjustable in position permits the driving-pinion E to be varied in size and a variation of speed of the cutting-tool to be secured.

For work requiring a very quick speed of the cutting-tool I drive the feed-shaft by the step H and pulley K, which, by the arrangement of gearing, has a speed much faster than the pulley M, a change in the size of both E and L allowing a wide range in variation of speed of the cutting-tool.

As the pulleys M and K turn in opposite directions it will be necessary to employ an open belt with one and a crossed belt with the other, in order to rotate the feed-shaft in the same direction.

When the tool is fed by the leading-screw, as in screw-cutting, the driving-belt is disconnected from the pulley upon the feed-shaft, and the intermediate gear, J, made to engage the gears E and G, the adjustment of the sleeve *d* in the slot *a* carrying with it the arm *f*.

The lever I and intermediate J, as concerned in the rotation of the feed-shaft, are entirely independent of the gear G on the leading-screw, but the lever I is made to turn on the leading-screw in the present instance, in order to allow the intermediate to be brought into mesh with both gears E and G; but it will readily be seen that in case the lathe is not a screw-cutting lathe and the cutting-tool only required to be fed by the rotation of the feed-shaft, the leading-screw would be entirely omitted, and the lever I might be pivoted at any convenient point on the bed of the lathe.

In case the lathe is intended only for such work as requires a very slow feed, the auxiliary pinion L and its belt-pulley K may be omitted and the pulley M alone used, a great variation in the feed being readily secured by varying the size of the driving-gear E; hence my present invention is specially adapted to those lathes known as "screw-cutting lathes," as in such lathes a large variety in sizes of gears are usually furnished in order to vary the speed of the leading-screw.

For the purposes of ordinary lathes the belt-pulley K and also the auxiliary pinion and pulley, as shown and herein described, are necessary in order to secure a wider range in the feeding motion of the cutting-tool. The scope of my invention is not limited, however, to the employment of both, as one may be omitted in case the character of the work does not require it.

What I claim as my invention, and desire to secure by Letters Patent, is--

1. The combination, with the feed-shaft of a metal-turning lathe, a belt-pulley on the feed-shaft, and a driving gear-wheel rotated by the live-spindle of the lathe, of a belt-pulley in alignment with the pulley on the feed-

shaft and a gear-wheel attached thereto, said pulley and attached gear-wheel being adjustable in their position relatively to said driving gear-wheel, whereby a change in the size of the driving-gear may be made, as described, and for the purpose set forth.

2. In a metal-turning lathe, the combination, with the live-spindle and feed-shaft of the lathe, of mechanism for conveying rotary motion from the live-spindle to the feed-shaft, said mechanism consisting of a pulley on the feed-shaft, a gear driven by the live-spindle, and a gear meshing therein and a pulley attached thereto, said pulley and gear being carried on a lever pivoted to the bed of the lathe and held in any desired position to engage said driving-gear, as described, and for the purpose set forth.

3. The combination, in a metal-turning lathe, with a feed-shaft having an attached belt-pulley, of mechanism for conveying rotary motion from the live-spindle to the feed-shaft, said mechanism consisting of a train of gears connected with and driven by the live-spindle of the lathe, two or more of the gears in said train being of varying size, and consequently of varying speed, and belt-pulleys attached thereto, each in alignment with a pulley on the feed-shaft, as described, and for the purpose set forth.

4. In a metal-turning lathe, the combination, with a feed-shaft having a belt-pulley attached, a gear driven by the live-spindle, and a gear held by and carried on an arm pivoted on the lathe, so as to be adjustable in position, of a pinion in mesh with said adjustable gear, and a belt-pulley attached to said pinion and in alignment with the belt-pulley on the feed-shaft, as described.

5. In a metal-turning lathe, the combination of a feed-shaft having a belt-pulley attached thereto, a gear driven by the live-spindle, a gear in mesh therewith and forming an intermediate gear, a pinion in mesh with said intermediate, and a belt-pulley attached to said pinion and in alignment with the belt-pulley on the feed-shaft, and said pinion and its attached belt-pulley being adjustable in position relatively to said intermediate, so as to allow the size of said pinion to be varied, as described, and for the purpose set forth.

6. The combination, with the intermediate gear, of a screw-cutting lathe, said intermediate gear being connected with and driven by the live-spindle, and being held in a slotted lever pivoted concentrically with the leading-screw, of a belt-pulley attached to said intermediate gear, and a pinion meshing with said intermediate gear, and a belt-pulley attached thereto, and a feed-shaft with an attached belt-pulley in alignment with the pulleys on said gears, as described.

JOHN R. BACK.

Witnesses:

RUFUS BENNETT FOWLER,
H. M. FOWLER.